



More information on the website
radwag.com/en/info,w1,LRI

PS 4500.R2.M Precision Balance



The drawings, photos and graphics used are for illustrative purposes only.

Functions



Autotest



Dosing



Percent Weighing



Totalizing



Parts counting



Peak hold



Newton unit measurement



Statistics



Checkweighing



GLP Procedures



Animal weighing



Density determination

Datasheet

Metrological parameters	
Maximum capacity [Max]	4500 g
Minimum load	0,5 g
Readability [d]	0,01 g
Verification unit [e]	0,1 g
Tare range	-4500 g
Minimum weight (USP)	10 g
Minimum weight (U=1%,k=2)	1 g

Metrological parameters	
Repeatability (Max)	0,008 g
Repeatability (5% Max)	0,005 g
Linearity	±0,02 g
Stabilization time	1,5 s
Adjustment	internal (automatic)
OIML Class	II
Sensitivity temperature drift	$2 \times 10^{-6} / ^\circ\text{C} \times \text{Rt}$
Physical parameters	
Leveling system	manual
Display	LCD (backlit)
Protection class	IP 43
Delivery components	Balance, weighing pan, weighing pan shield, power supply
Weighing pan dimensions	195x195 mm
Device dimensions	333x206x107 mm
Packaging dimensions	465x370x290 mm
Net weight	4 kg
Gross weight	6 kg
Communication interface	
Communication interface	2xRS232 ¹ , USB-A, USB-B, Wi-Fi (option)
Electrical parameters	
Power supply	Adapter: 100 – 240V AC 50/60Hz 0,6A; 12V DC 1,2A Balance: 12 – 15V DC 0,4A max
Power consumption	4 W
Environmental conditions	
Operating temperature	+10 ÷ +40 °C
Storage temperature	-20 ÷ +50 °C
Relative humidity	40% ÷ 80%

Repeatability is expressed as a standard deviation from 10 weighing cycles. Stabilization time depends on the ambient conditions and the dynamics of weighing pan loading; specified for FAST profile. 1 Barcode scanners, available as weighing instrument accessory, communicate with the instrument via RS232 interface exclusively.

* Wi-Fi® is a registered trademark of Wi-Fi® Alliance.



Extra payment for verification



Accessories

Balance Storage Case
Power Adapters
Barcode scanners
Cigarette lighter receptacle power supply cables
USB cable (scale - printer)
Displays
Density determination KIT

Protective cover for balances
Receipt Printer
THBR 2.0 System - Ambient Conditions Monitoring
RS 232, RS 485 cables
Under-pan weighing
RS 232 cables (scale - printer)

Software

RAD-KEY
R Panel
R-LAB
E2R System

LabVIEW Driver
Alibi Reader
RADWAG Development Studio
R.Barcode

Device dimensions

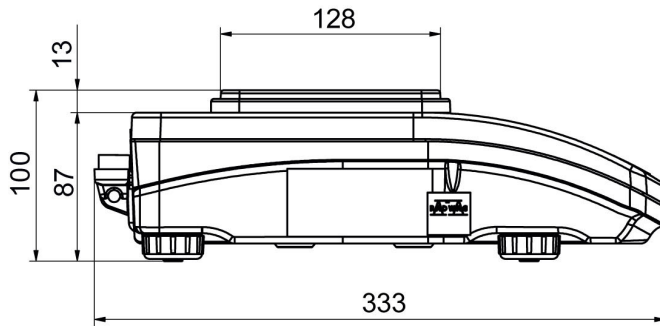

PS R, d = 1 mg

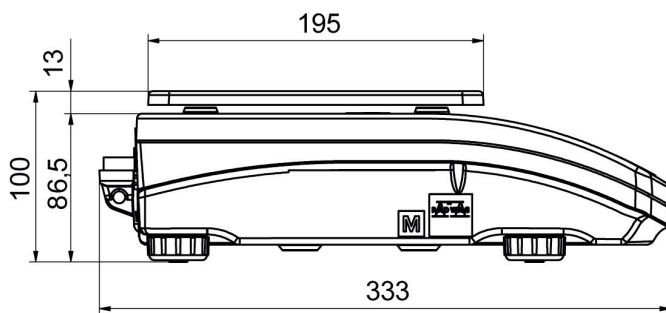
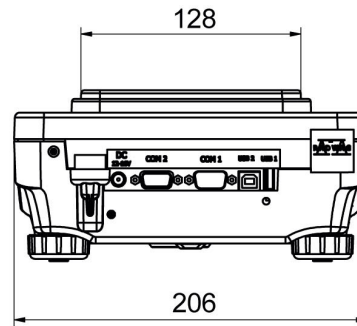

PS R, d = 10 mg

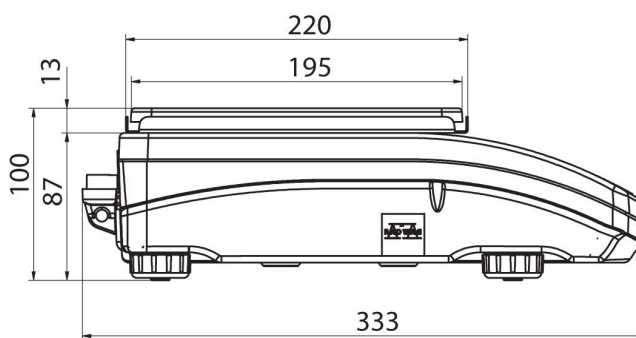
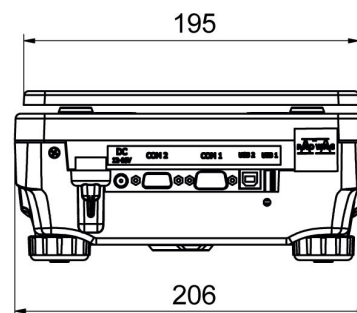

PS R.M, d = 10 mg

